

QUADRA-FIRE

North America's Best

Installation, Operation, and Maintenance Instructions Model: Quadra-Fire 1800 FreeStanding

Clean Air

We Care

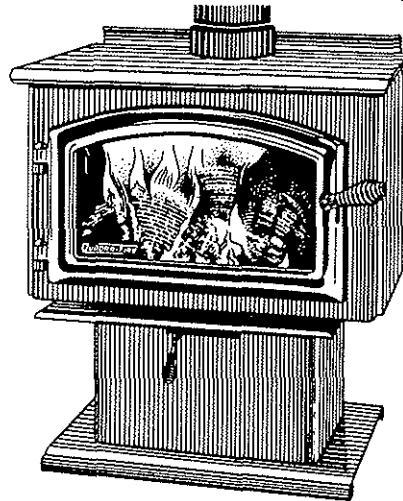

Also Available in French
Ask Your Dealer

Nous Avons Aussi Le Manuel en Francais.
Demandez á Votre Vendeur

CONGRATULATION -- You are now the proud owner of one of the finest inserts in the world for your home -- the **QUADRA-FIRE.**

Now, before installing your insert and building your first fire -- record the serial number on the warranty card.

PLEASE READ ALL OF THE OWNERS MANUAL AND SAFETY NOTES.

IMPORTANT SAFETY NOTES:

1. When installing your stove, particular attention should be paid to fire protection. If this unit is not properly installed, a house fire may result. For your safety, follow the installation instructions and contact local building or fire officials about restrictions and installation inspection requirements in your area.
2. Never use gasoline or similar liquids to start a fire in this unit. Keep all such liquids well away from stove.
3. During operation, if any part of the stove starts to glow, the stove is in an overfired condition. Close the air controls completely until the glowing has stopped. **OVERFIRING VOIDS WARRANTY.**
4. Cool ashes should be disposed of carefully - using a metal container.
5. Do not burn wet or green wood. Store wood in dry location.
6. Do not burn garbage, treated wood, or wood with salt (driftwood, etc.).
7. Do not permit creosote or soot to accumulate excessively in the chimney or inside the firebox.
8. Check your chimney system thoroughly when installing into an existing metal or masonry chimney. Seek professional advice if in doubt about its condition.
9. Do not connect this unit to a chimney flue already serving another appliance.
10. Comply with all minimum clearances to combustibles as shown in this manual.
11. Build fire on brick firebox floor -- **Do not use grates, andirons or other method to support fuel.**
12. Hot while in operation. Keep children, clothing and furniture away. Contact can cause skin burns.
13. Do not connect to any air distribution duct or system.

ALADDIN

ALADDIN STEEL PRODUCTS, INC.

401 N. WYNNE

COLVILLE, WASHINGTON 99114

SAVE THESE INSTRUCTIONS

NOTES

TABLE OF CONTENTS

	Page
Installation Materials Needed	3-4
Installation	4
Clearances To Combustibles	4
Floor Protector	4
Venting System	5
Chimney Connector	5
Connection To A Masonry Chimney	5-6
Chimney	6-7
Thimble	7-8
Brick Chimney Thimble Assembly	8
6 Inch Solid Pack chimney With Metal Supports	9
Connection To A Masonry Chimney	9
Connection To A Metal Prefabricated Chimney	12
Mobile Home Installation Outside Combustion Air	13
Operating Instructions	14
Combustion Air Systems	14
Fan Operating Instruction	14
Operating Tips	14
Building A Fire	15
Care & Cleaning Of Glass & Plated Surfaces	16
Ash Removal	16
Firebrick	16
Wood Selection & Storage	16
Brick Patterns	17
Maintenance Instructions	17
Creosote Formation Inspection & Removal	17
Top Heat Shield	18
Door Handle & Glass Replacement	19
Optional Blower Instruction	20
Baffle Removal & Installation	21-22
Warranty	23

INSTALLATION MATERIALS NEEDED FOR YOUR SAFETY

CHIMNEY CONNECTOR: (Also known as flue pipe or stove pipe) The chimney connector joins the stove chimney. It should be 6 in. diameter 24 MSG black or blue steel 24 gauge minimum.

THIMBLE: A manufactured or site-constructed device installed in combustible walls through which the chimney connector passes to the chimney. **It is intended to keep walls from igniting.**

The **Quadra-Fire 1800** was safety tested and is listed by Warnock Hersey INC. to UL 1482 and ULC S627.

Also approved for mobile home installation with outside combustion air. (Kit Order #821-0240 & #821-0230)

WARNING: "DO NOT INSTALL IN SLEEPING ROOM"

CAUTION: THE STRUCTURAL INTEGRITY OF THE MOBILE HOME FLOOR, WALL AND CEILING/ROOF MUST BE MAINTAINED.

In a residential installation in Canada without an outside combustion air kit a source of fresh air into the room shall be provided.

CHIMNEY: APPROVED MASONRY (see specification on page 5), with at least 5/8" fire clay lining joined with refractory cement or other listed system suitable for use with wood stoves

OR

PREFABRICATED 6 in. listed high temperature (UL 103 or ULC 629M) chimney. Components required by manufacturers for installation such as the chimney support base, firestop (as appropriate), attic insulation shield, insulated tee, etc., are necessary to assure a safe chimney installation. Use only components manufactured for the chimney.

CLEARANCE TO COMBUSTIBLES

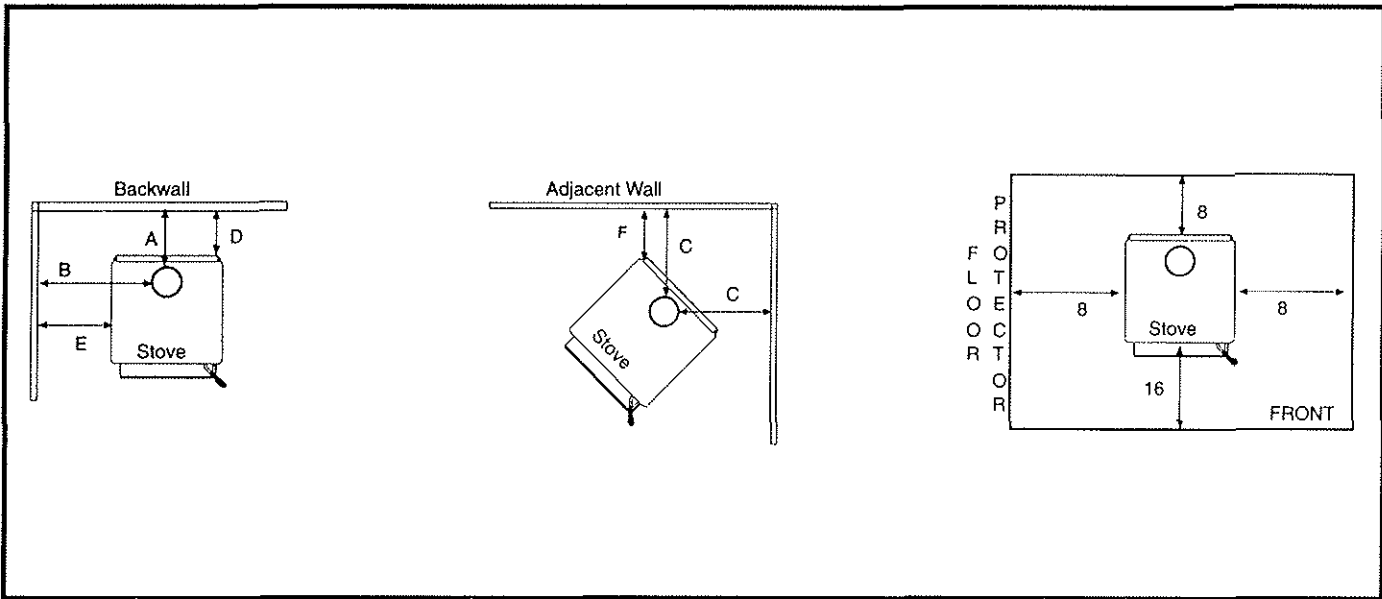

Minimum Clearance To Combustible (In Inches And Millimeters)

Installation	Clearance	Chimney & Connector	Dimensions					
			A	B	C	D	E	F
Residential	Standard	Note 1	18"(457mm)	24"(610mm)	21"(533mm)	16"(406mm)	15"(381mm)	12"(305mm)
Residential/ Mobile Hm.	Reduced	Note 2	12"(305mm)	24"(610mm)	21"(533mm)	10"(254mm)	15"(381mm)	12"(305mm)
Alcove	Standard	Note 2 & 3	12"(305mm)	24"(610mm)	21"(533mm)	10"(254mm)	15"(381mm)	12"(305mm)

Minimum clearances to combustible material with double-wall chimney connector and top heat shield (Part #831-1260)

Installation	Clearance	Chimney & Connector	Dimensions					
			A	B	C	D	E	F
Residential/ Mobile Hm.	Reduced	Note 2 & 3	8"(203mm)	20"(508mm)	17"(432mm)	6"(152mm)	11"(279mm)	8"(203mm)

Note 1: 6 in. diameter single, minimum 24 MSG steel connector pipe with a listed factory-built chimney or a masonry chimney.

Note 2: 6 in. diameter double wall air insulated connector pipe with listed factory-built chimney or a masonry chimney.

Note 3: Alcove maximum depth of no more than 48", and an alcove ceiling height of 84" -- with top heat shield (Part #831-1260) and double-wall chimney connector alcove ceiling height is 72".

When locating your stove, consider safety, convenience, traffic flow and the fact that the stove will need a chimney and chimney connector.

Floor protector must be non-combustible material, extending beneath heater and to the front, sides and rear as indicated.

AVOID FIRE: Maintain the designated clearance distance to combustibles. Insulation must **NOT** touch the chimney. There must be the designated air space clearance around the chimney. This air space around a chimney is necessary to allow natural heat removal from the area. Insulation in this space will cause a heat buildup which may ignite wood framing.

VENTING SYSTEM

The venting system consists of a chimney connector and a chimney. These get extremely hot when the stove is being used. Temperatures inside the chimney may exceed 2000° in the event of a creosote fire. To protect against the possibility of a house fire, the chimney connector and chimney must be properly installed and maintained. A thimble **Must** be used when a connection is made through a combustible wall to a chimney. A chimney support package **Must** be used when a connection is made through the ceiling to a prefabricated chimney. These accessories are absolutely necessary to provide safe clearances to combustible wall and ceiling material.

This stove may be connected to a lined masonry chimney or a listed high temperature prefabricated residential type building heating appliance chimney. Do not connect it to a chimney serving another appliance. To do so will affect the safe operation of both appliances.

CHIMNEY CONNECTOR

The chimney connector must be 6 in. diameter pipe with a minimum thickness of 24 gauge. Do not use aluminum or galvanized steel. They cannot properly withstand the extreme temperatures of a wood fire. Do not use chimney connector pipe as a chimney. You must connect your stove to a chimney at least equal to those specified in this manual.

Chimney connector sections must be attached to the stove and to each other with the crimped end toward the stove. This allows creosote to run into the stove and not onto the outside of the pipe. All joints should be secured with three metal screws. Otherwise, in the event of a creosote fire, the connector may come apart due to movement.

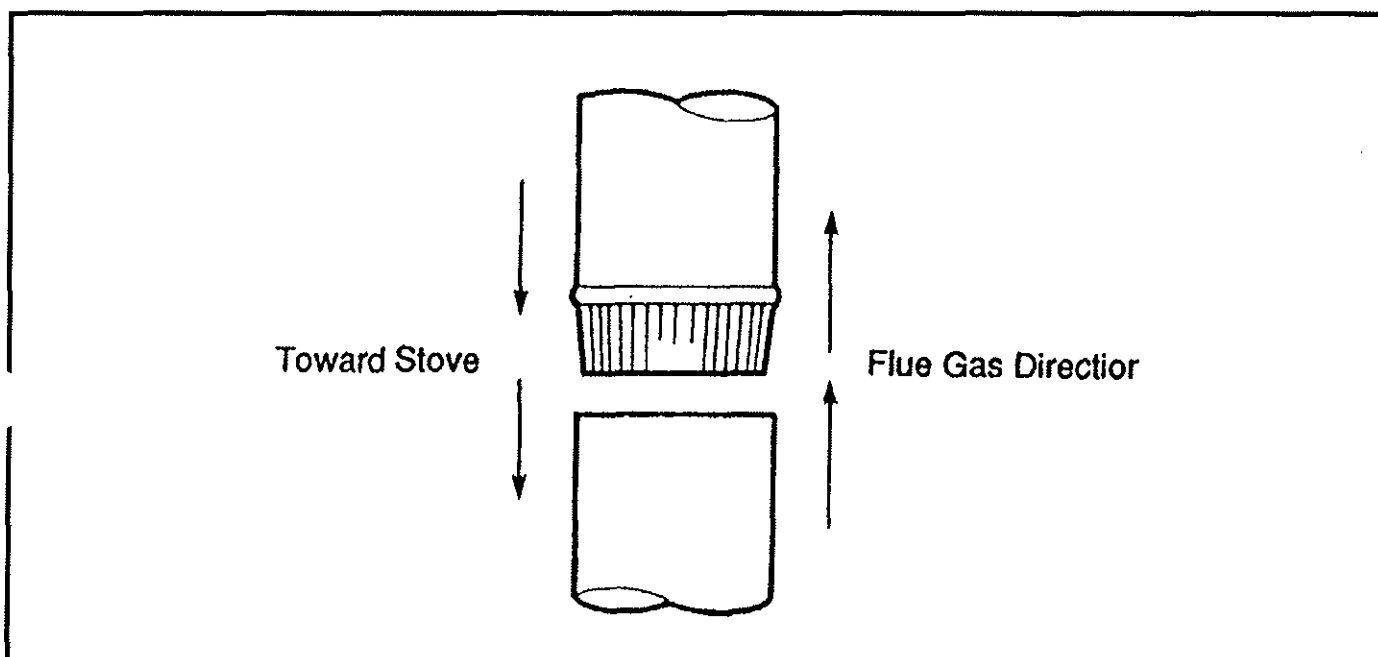

For proper operation the chimney connector should be as short as possible. Horizontal lengths of chimney connector should have a minimum upward slope from the stove of at least 1/4 in. per foot.

CHIMNEY HEIGHT/DRAFT

To insure that your **Quadra-Fire** stove burns properly, the chimney draft (Static Pressure) should be approximately 0.100 in. water column (W.C.) during a high burn and 0.040 in. W.C. during a low burn, measured 6 in. above the top of the stove after one hour of operation at each burn setting.

Your **Quadra-Fire** stove was designed and tested on a 6 in. chimney, 12 - 14 feet high, measured from the top of the stove. The further your stack height or diameter varies from this configuration, the probability of performance problems increases. In addition, exterior conditions such as roofline, surrounding trees, prevailing winds and nearby hills can influence stove performance.

CONNECTION TO A MASONRY CHIMNEY

1. Chimney -- Should the stove be connected to a masonry chimney, the chimney should be examined for cracks, loose mortar and other signs of deterioration as well as blockage. The stove should not be installed until it is determined the chimney is safe to use. Since an oversized flue contributes to the accumulation of creosote, the size of the flue should be checked to determine that it is not too large for the stove. The chimney should also be checked to assure it meets the minimum standards of the National Fire Protection Association (NFPA) Standard 211. The following is a list of the more critical minimum requirements for a properly constructed chimney.

1. The masonry wall of the chimney, if brick or modular block, must be a minimum of 4 in. nominal thickness. A mountain or rubble stone wall must be at least 12 in. thick.
2. The chimney must have a fire clay flue liner (or equivalent) with a minimum thickness of 5/8 in. and must be installed with refractory mortar. There must be at least 1/2 in. air space between the flue liner and the chimney wall. A equivalent liner must be a listed chimney liner system or other approved material.

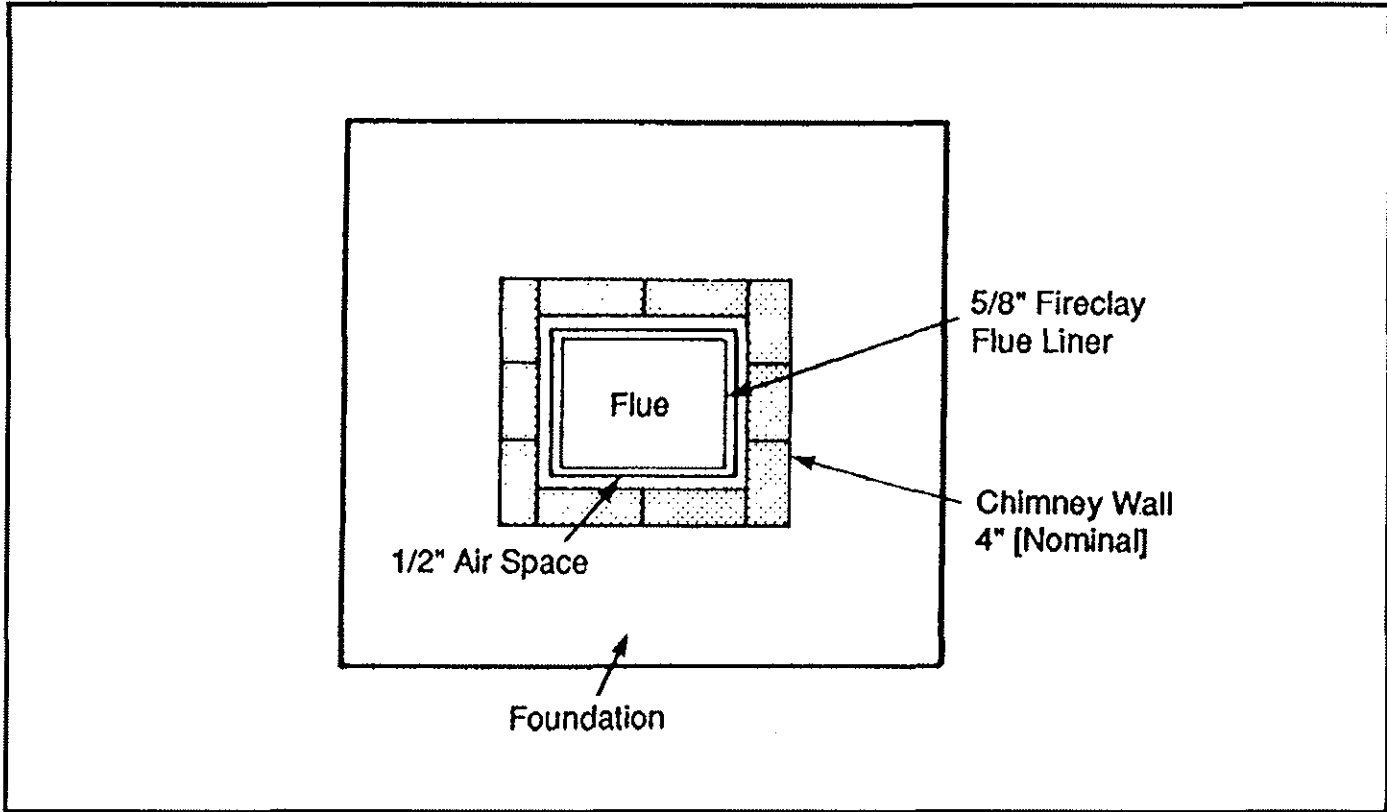

- A chimney inside the house must have a least 2 in. of clearance to any combustible material. A chimney outside the house must have at least one in. clearance to any combustible material. Fire stops must be installed at the spaces where the chimney passes through floors and/or ceilings.

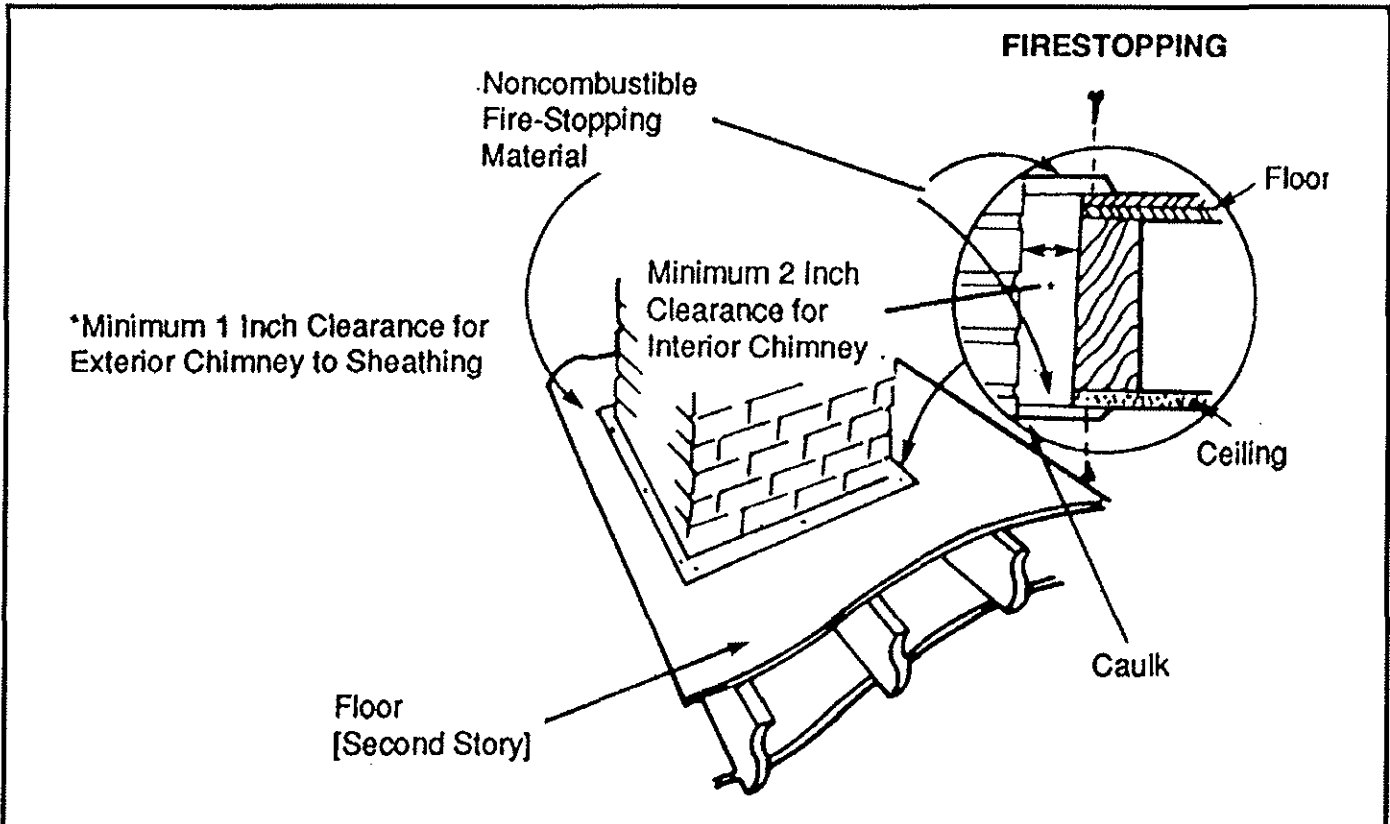

Remember that insulation must not contact the chimney. There must be an air space around the chimney and any insulation must be at least 2 in. or more from the chimney.

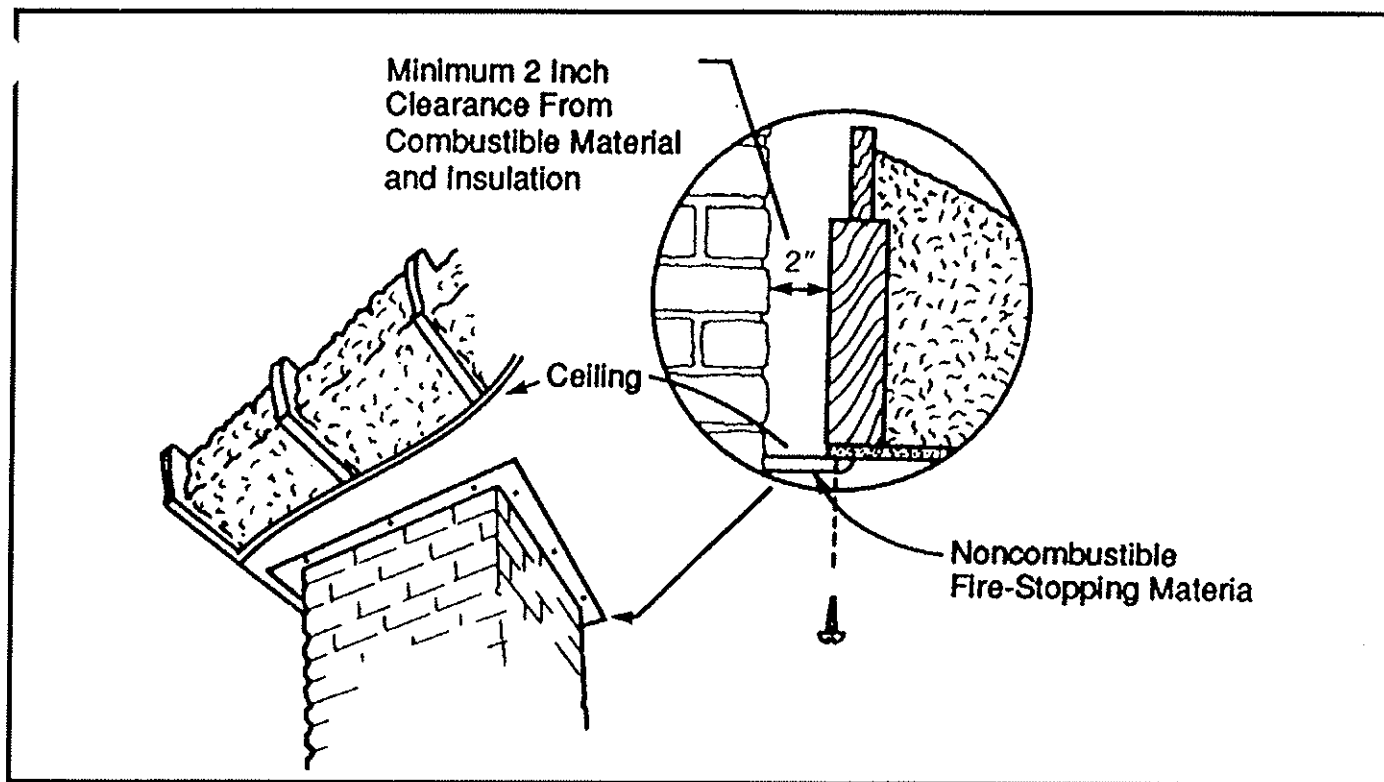

- A chimney must be the required height above the roof or other obstruction for safety and for proper draft operation. The chimney must be at least 3 feet higher than the highest point where it passes through the roof and at least 2 feet higher than the highest part of the roof or structure that is within 10 feet of the chimney, measured horizontally.

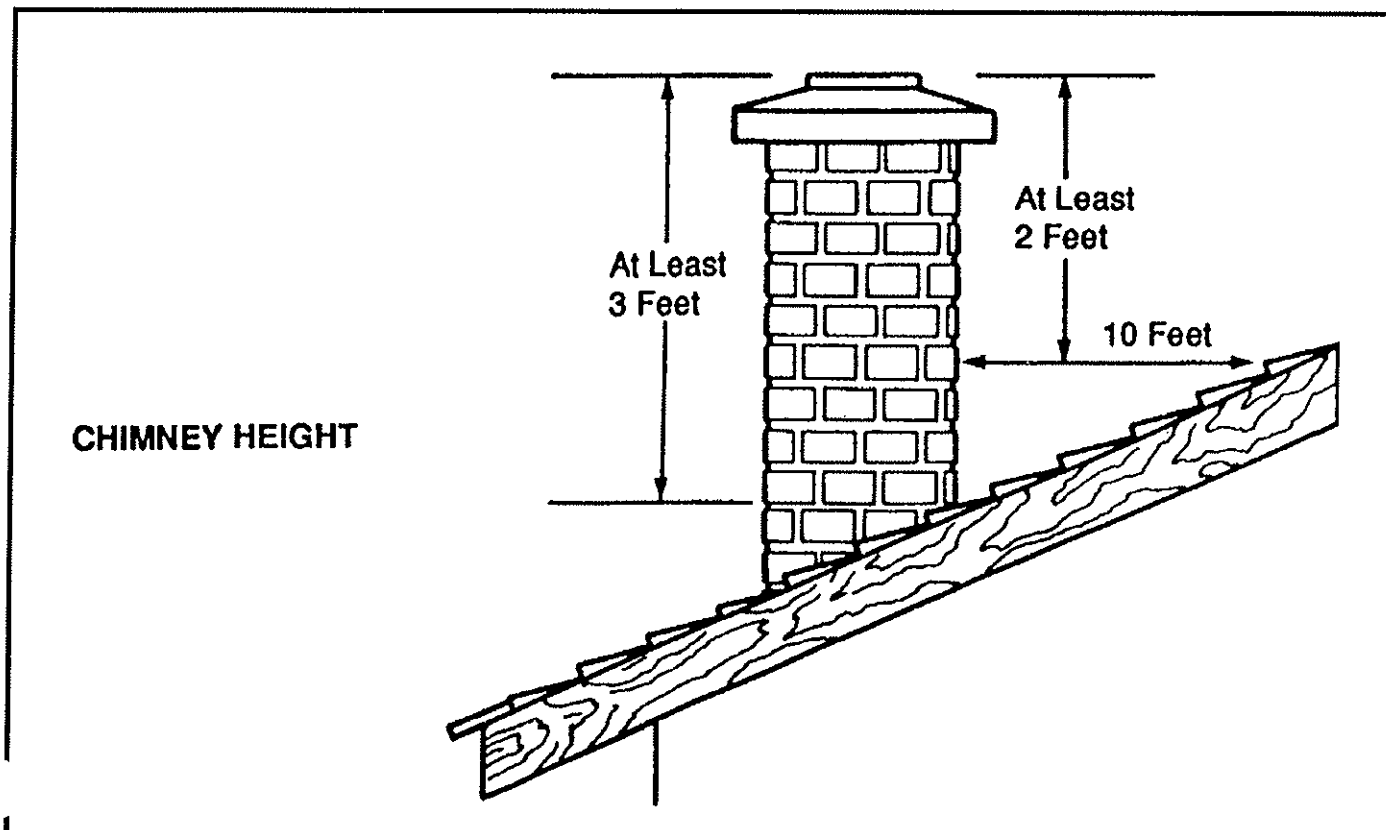

II. Thimble -- A thimble must be used when the connection from the stove is made through a combustible wall to a masonry chimney. There are several methods to use for connections made through a combustible wall, two of which are illustrated in this manual. Local building authorities may be consulted or (NFPA) 211 may be used for additional methods of chimney connection.

Also, listed prefabricated metal thimbles can be bought for use with wood stoves. The manufacturer's installation instructions for a thimble must be strictly followed to assure the safety of the system. Be sure to maintain the designated clearance to combustible materials.

1. **Brick chimney thimble assembly** -- Construction of a brick thimble assembly requires 12 in. of brick around a fire clay liner. Be sure the point of penetration allows a 24 in. clearance from the top of the connector to the ceiling. An opening of 30 in. (for a 6 in. chimney connector) must be cut in the wall to maintain the required 12 in. of brick separation from combustibles. It will be necessary to cut wall studs and install a header and sill frame to maintain the proper dimensions and to hold the weight of the brick.

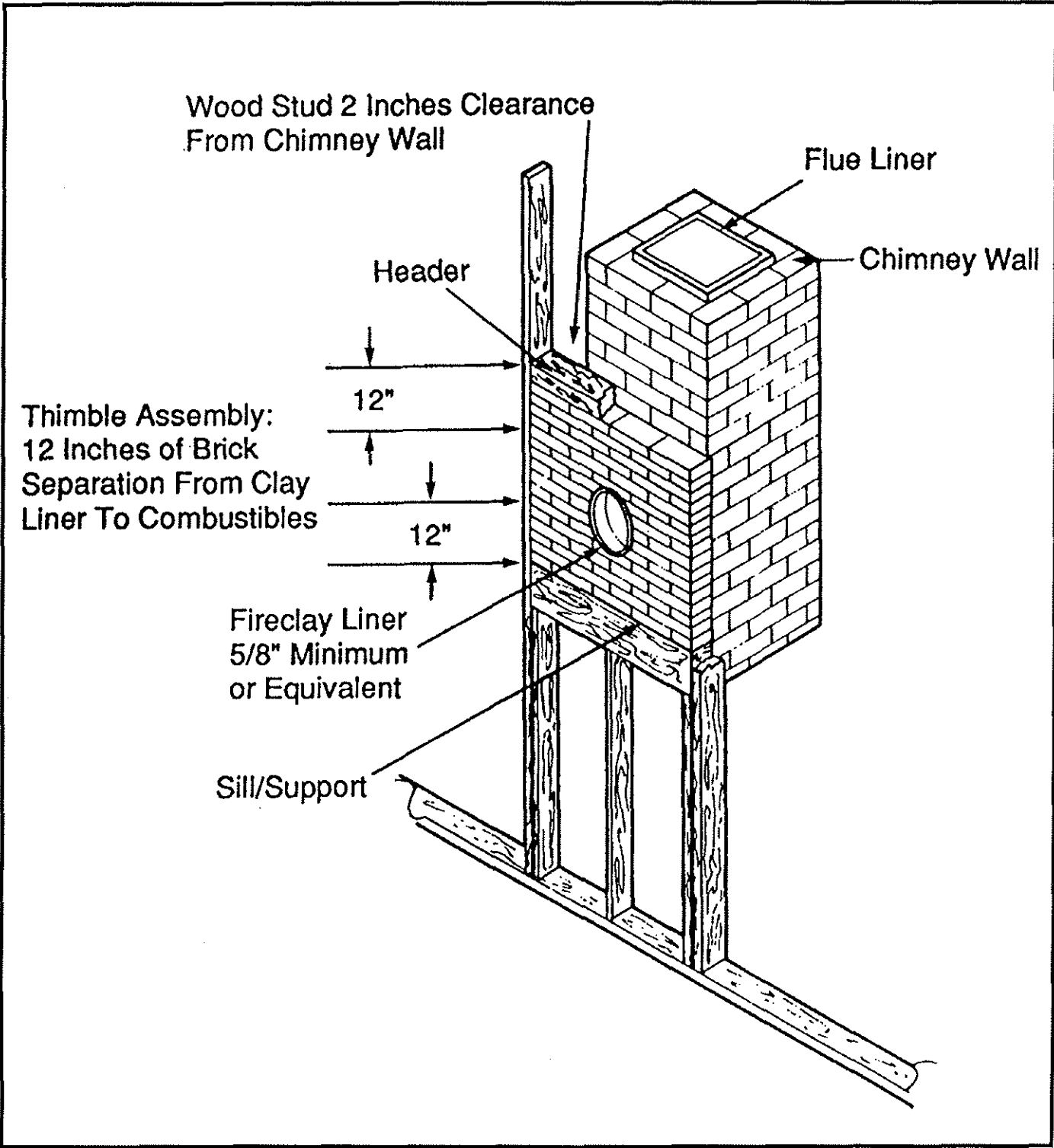

Minimum 3-1/2 in. (4 in. nominal) thick solid bricks are to be used. The fire clay liner (ASTM C35 or equivalent) minimum 5/8 in. wall thickness, must not penetrate into the chimney beyond the inner surface of the chimney flue liner and must be firmly cemented in place. If it is necessary to cut a hole in the chimney liner, use extreme care to keep it from shattering. Refractory mortar must be used at the junction to the chimney liner. After the assembly is complete, insert the chimney connector in the fire clay liner. Do not push it beyond the inside edge of the chimney liner because this will affect the draw of the chimney.

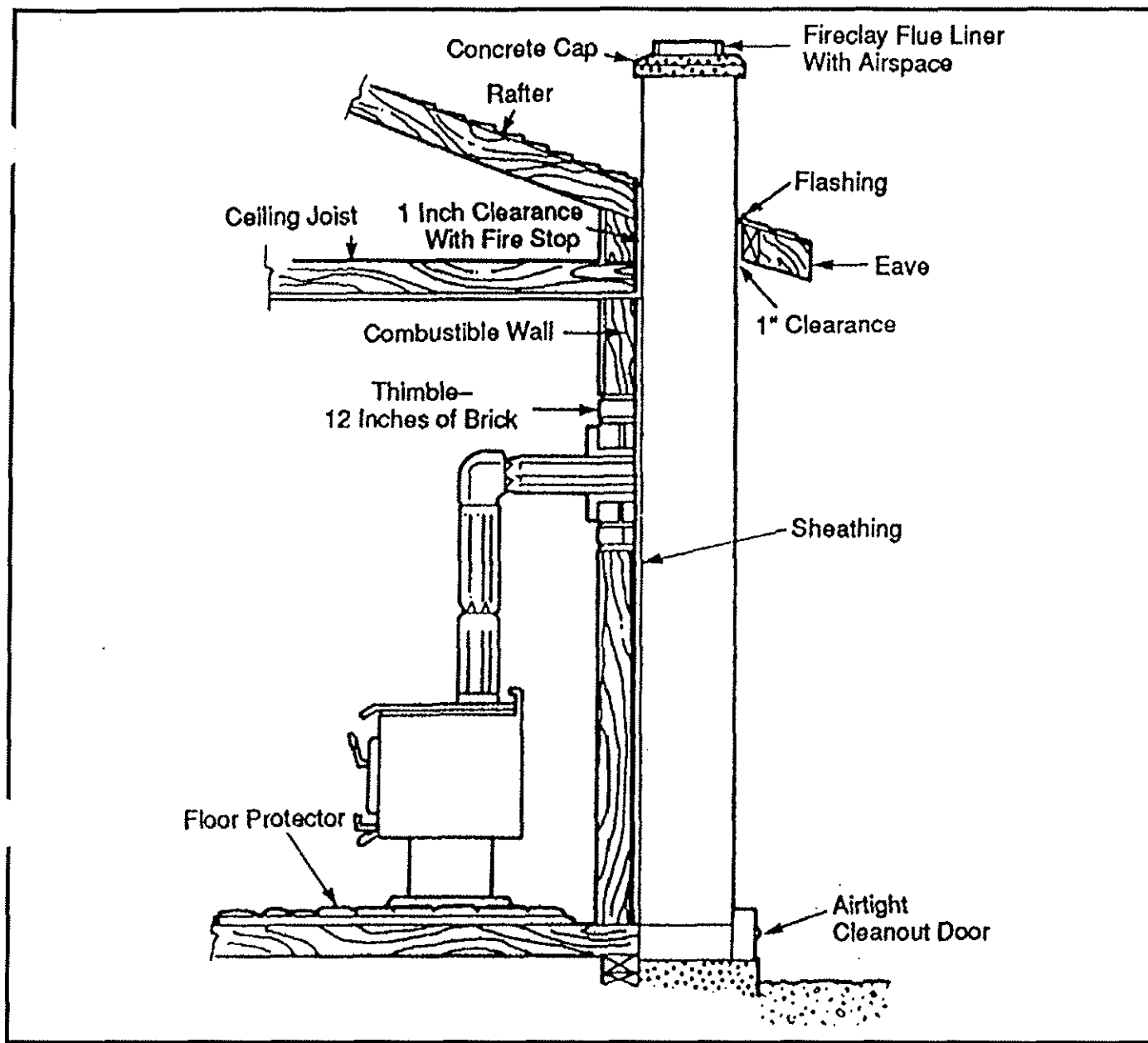

2. 6 in. solid pack chimney with metal supports as a thimble -- For the method of installation to a masonry chimney shown, it will be necessary to purchase a 8 in. inside diameter 12 in. long section of prefabricated listed solid chimney to use a thimble. Purchase a wall spacer, trim collar and wall band that are manufactured to fit the chimney section you purchase.

The safety features of this system are the 2 in. air space between the chimney section and combustible wall and the 1 in. air space around the chimney connector where the connector passes through the chimney section to the chimney.

The location of the opening through the wall to the chimney must leave a minimum 24 in. vertical clearance between the connector pipe and the ceiling to prevent the ceiling from catching fire.

Cut out a 14-1/2 in. diameter opening in the wall. It may be necessary to cut wall studs and install a header and sill frame to maintain the wall support. The hole in the chimney must have at least a 6 in. diameter fire clay liner or equivalent secured with refractory mortar. If it is necessary to cut a hole in the chimney liner, use extreme care to keep it from shattering.

First, make the frame for the thimble, being sure it is no smaller than 14-1/2 in. diameter, to maintain a 2 in. air space around the chimney section. Attach the wall spacer to the chimney side of the frame. Then insert the frame into the opening, toe-nailing it to the wall studs. Install the wall band in the framing to secure the chimney section in place. Insert a single section of chimney connector to the chimney through the wall band, being sure it does not protrude into the chimney beyond the edge of the chimney flue lining. Apply high temperature furnace cement to the end of the chimney section and install it over the connector, through the wall spacer. Tighten the wall band to hold the chimney section firmly in place and against the chimney. Install the trim collar on the outside of the opening. Check to assure there is a 1 in. air space between the connector and the chimney section. Also, during installation, always check to assure that a 2 in. air space is being maintained to the wood framing. Do not fill this space with insulation. Insulation in this air space will cause a heat buildup which could ignite the wood framing.

**Minimum Chimney Clearance
to Wall Spacer and
Combustibles 2 Inches**

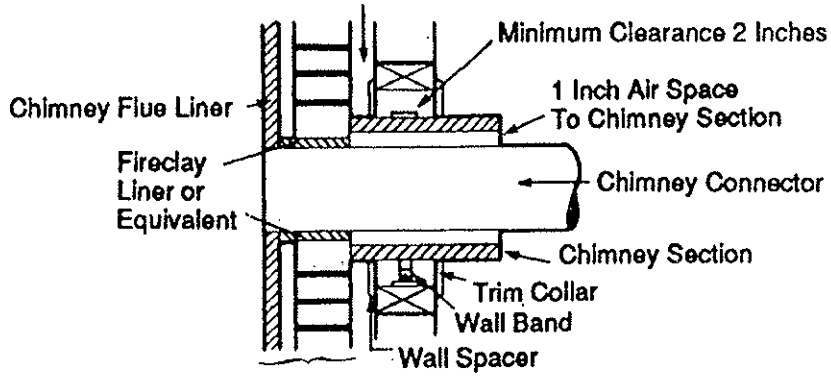

**Masonry
Chimney Constructed
to NFPA 211**

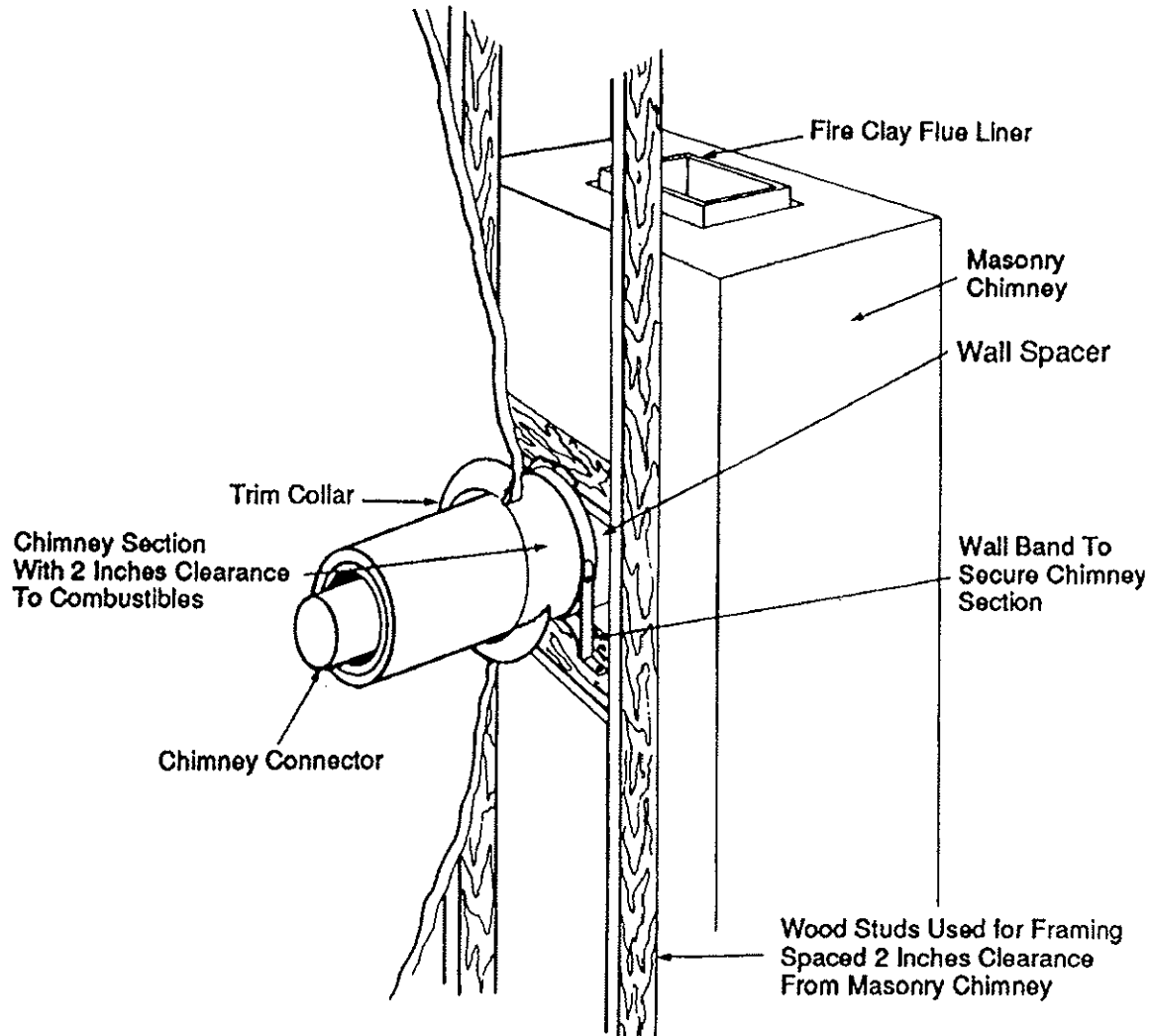

CONNECTION TO A METAL PREFABRICATED CHIMNEY

When a metal prefabricated chimney is used, the chimney manufacturer's installation instruction must be followed precisely. You must also purchase (from the same manufacturer) and install the ceiling support package or wall pass through and "T" section package, firestops (when needed), insulation shield, roof flashing, chimney cap, etc. Maintain the proper clearance to the structure as specified by the manufacturer. This clearance is usually a minimum of 2 in., although it may vary by manufacturer or for certain components.

Note 1: 6 in. diameter, minimum 24 MSG steel connector pipe with a listed factory-built chimney for a masonry chimney.

Note 2: 6 in. diameter double wall air insulated connector pipe with listed factory-built chimney or a masonry chimney.

Note 3: Alcove maximum depth of no more than 48", and an alcove ceiling height of 84" -- with top shield (Part #831-1260) and double-wall chimney connector alcove ceiling height is 72".

	A		B		C	
NOTE 1:	16 in.	406mm	18 in.	457mm	18 in.	457mm
NOTE 2:	10 in.	254mm	12 in.	305mm	10 in.	254mm
NOTE 3:	6 in.	150mm	8 in.	200mm	8 in.	200mm

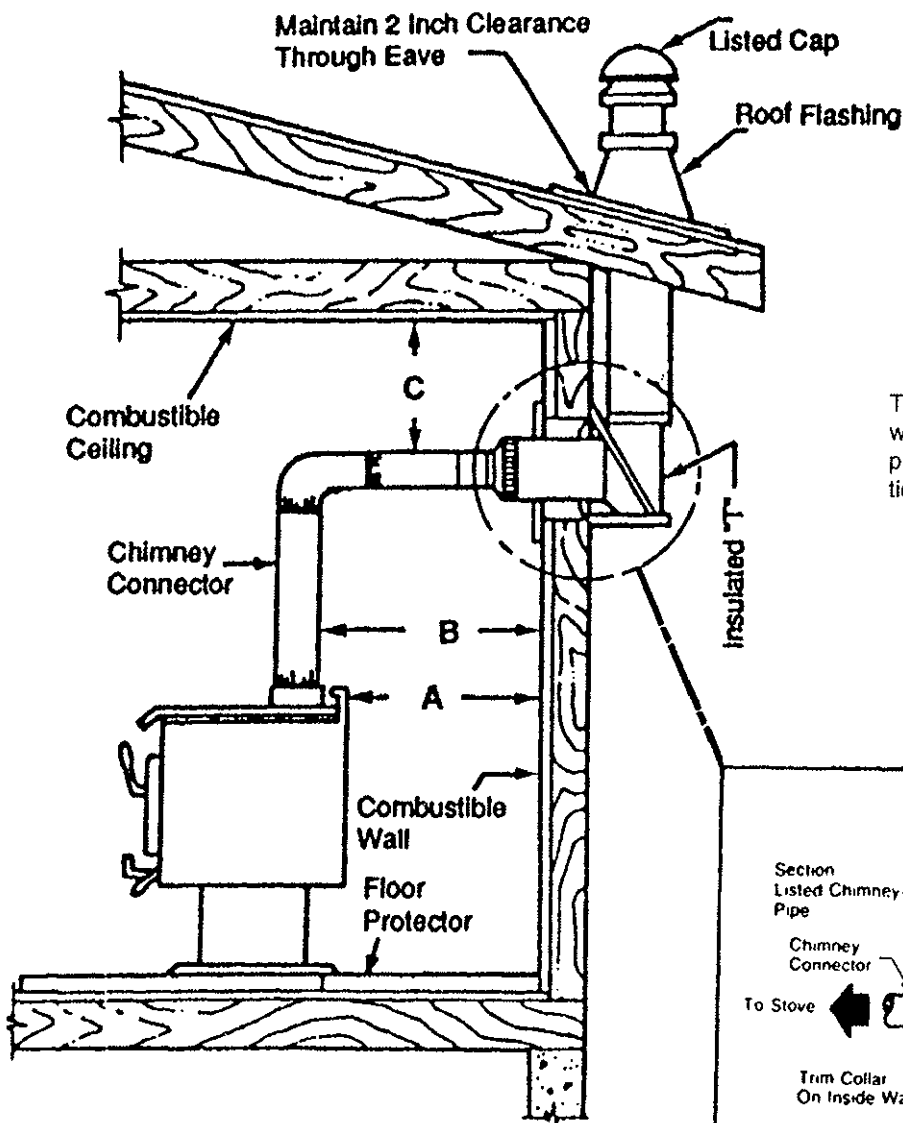

This method of installation requires a wall pass through device, a wall support package, and insulated "T" section and a roof flashing.

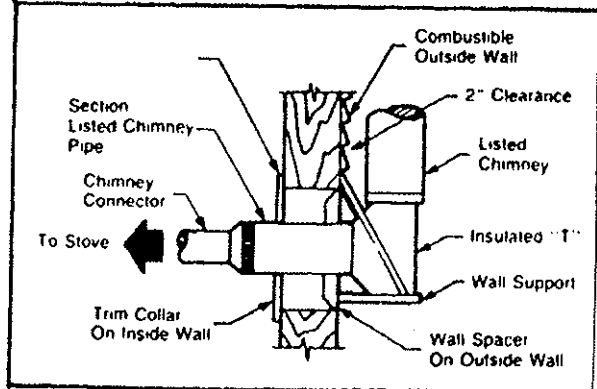

There are basically two methods of metal chimney installation. One method is to install the chimney inside the residence through the ceiling and the roof. The other method is to install an exterior chimney that runs up the outside of the residence. The components illustrated may not look exactly like the system you purchase, but they demonstrate the basic components you will need for a proper and safe installation.

The chimney must be installed so that it is the required height above the roof or other obstruction for safety and for proper draft operation. The requirement is that the chimney must be at least 3 feet higher than the highest point where it passes through the roof and at least 2 feet higher than the highest part of the roof or structure that is within 10 feet of the chimney, measured horizontally.

REMEMBER: Follow the manufacturer's installation instruction and maintain the manufacturer's specified clearance distances.

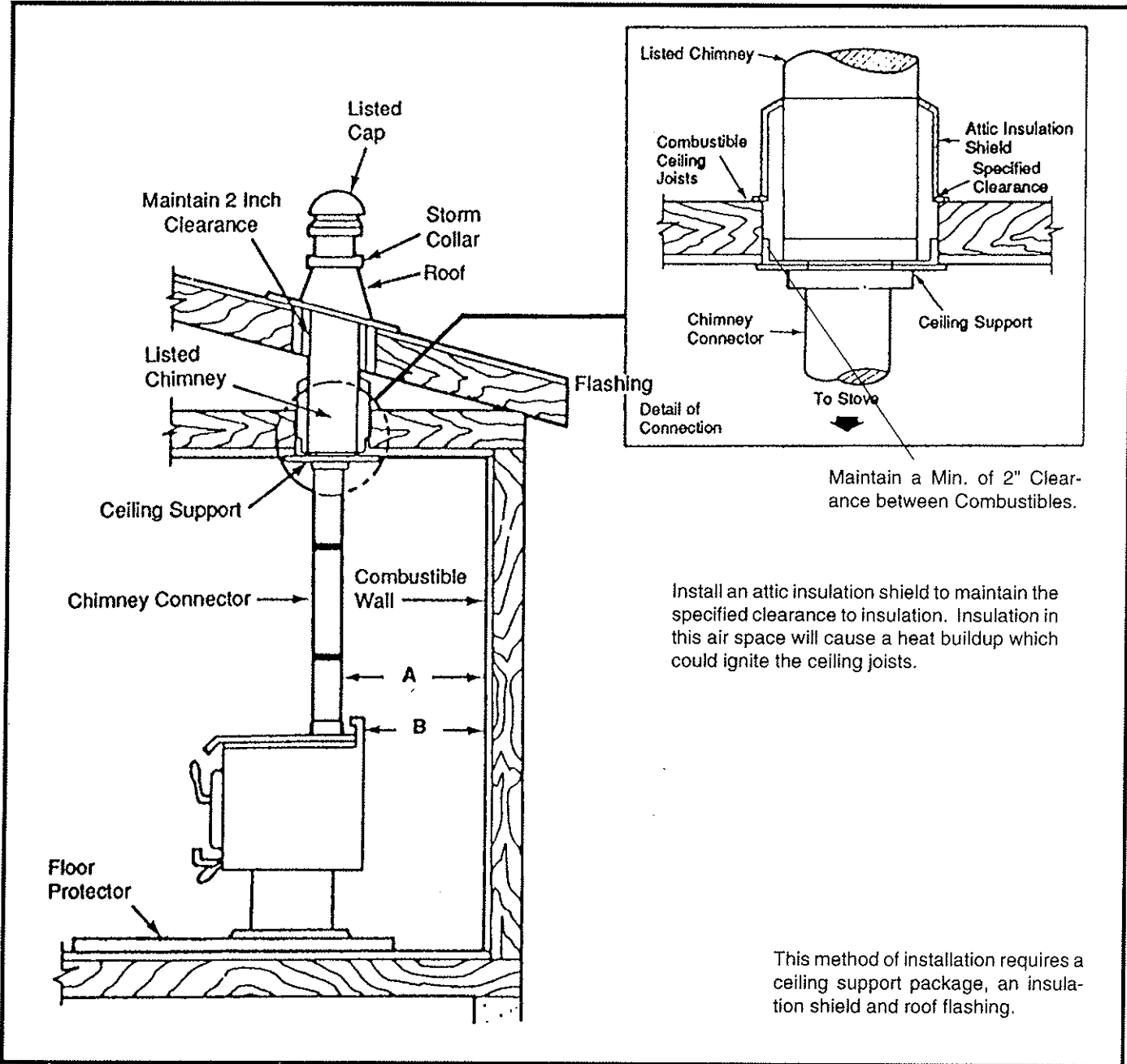

Minimum Clearance To Combustible Materials (In inches & mm) For Quadra-Fire 1800

Installation	Clearance	Chimney & Connector	Dimensions	
			A	B
Residential	Standard	Note: 1	18"(457mm)	16"(406mm)
Residential/Mobile	Reduced	Note: 2	12"(305mm)	10"(254mm)
Alcove	Standard	Note: 2 & 3	12"(305mm)	6"(152mm)
Residential/Mobile Home with double-wall connector and top heat shield			8"(203mm)	6"(152mm)

SEE Page 3 For Notes

OUTSIDE COMBUSTION AIR IS REQUIRED FOR MOBILE HOME INSTALLATION

Order #821-0230 Pedestal, Rear Intake
Order #821-0240 Pedestal, Thru Floor Intake

- Position the two side channels over the side air intakes and thru the holes in the sides of the pedestal and attach with (2) 8-32 screws.
- Mount front cover over the front air intake with (2) 1/4"-20 screws.
- Mount cover plate over the opening in the rear of the pedestal. (This plate may have a 3 feet tube for thru-the-wall installation.)
- Seal the sides of the pedestal base with fiberglass rope supplied.
- Cover hole in hearth beneath the pedestal with rodent screen. (Thru-the-floor installation only.)

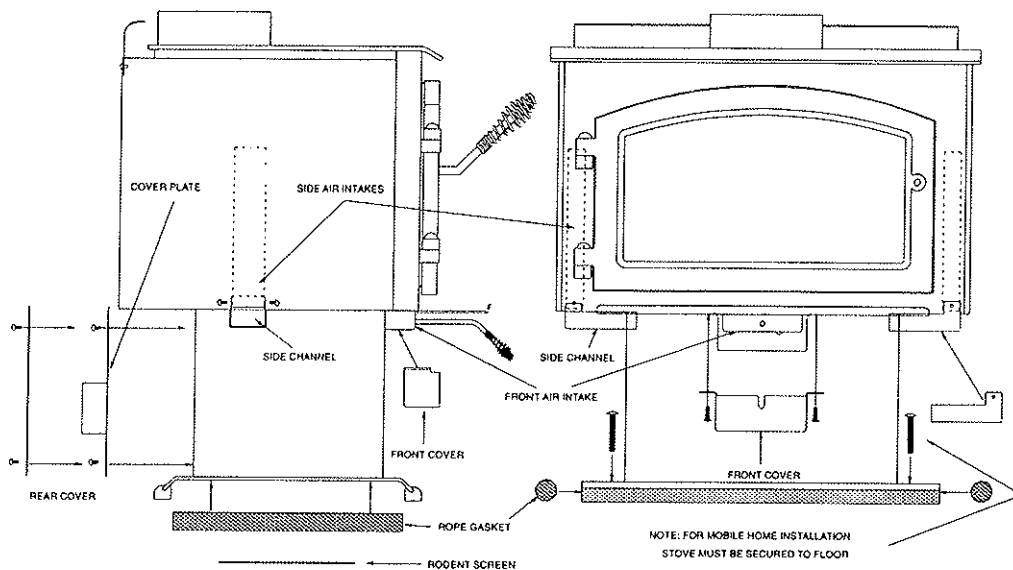

Order #831-1310 Leg, Rear Intake
Order #831-1300 Leg, Thru-Floor Intake

- Position the two side channels over the side air intakes and thru the holes in the sides of the bottom pan and attach with (2) 8-32 screws.
- Mount front cover over the front air intake with (2) 1/4"-20 screws.
- Mount floor or wall intake on underside of bottom pan and connect to ducting.

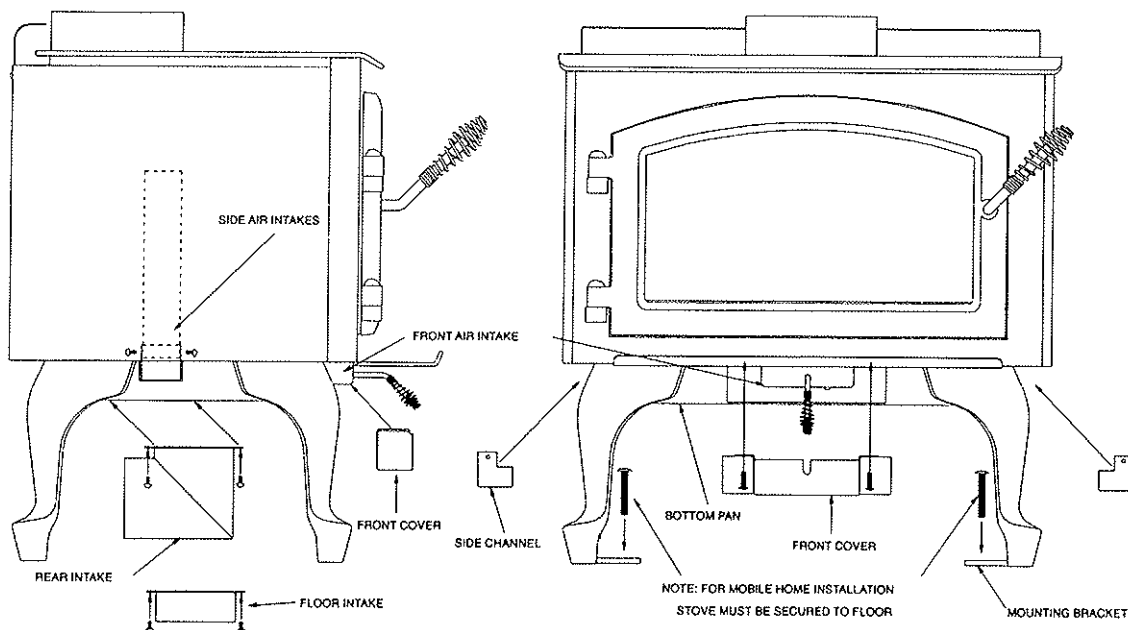

IMPORTANT, PLEASE READ BEFORE USING STOVE

In recent years there has been an increasing concern about the quality of air. Much of the blame for poor air quality has been placed on the burning of wood for home heating. In order to improve the situation, we at **Quadra-Fire** have developed cleaner-burning woodstoves that surpass the requirements for emissions established by agencies governing air quality.

These woodstoves, like any other appliance, must be operated properly in order to insure that they perform the way they should. Improper operation can turn any woodstove into a smoldering environmental hazard.

It helps to know a little about the actual process of burning in order to understand what goes on inside a stove. The first stage of burning we will call the **Kindling Stage**. This is when the wood is initially heated to a high enough temperature to evaporate the moisture which is found in all wood. The fuel will reach the boiling temperature of water (212° F) and will not get any hotter until the water is evaporated. This process takes heat from the coals and tends to cool the stove. Fire requires three things: Fuel, Air and Heat. So if heat is robbed from the stove during the drying stage, the new load of wood has reduced the chance for a good clean burn. For this reason it is always best to burn dry seasoned firewood. This isn't always possible. Sometimes the wood isn't dry, so you must open the control and burn the stove at the high burn setting for a longer time to start the wood burning. Pushing the air control in, opens it.

The next stage of burning, the **Secondary Stage**, is the period when the wood gives off flammable gases which burn above the fuel with bright flames. During this stage of burning it is most important that the flames be maintained and not allowed to go out. This will insure the cleanest possible fire. If you are adjusting your stove for a low burn rate, you should close down the air to the point where you can still maintain some flame. If the flames tend to go out, the stove is set too low for your burning conditions.

The final stage of burning is the **Charcoal Stage**. This happens when the flammable gases have been mostly burned and the charcoal remains. This is a naturally clean portion of the burn. The coals burn with hot blue flames. It is very important to reload your stove while enough lively hot coals remain in order to provide the amount of heat needed to dry and rekindle the next load of wood. It is best to open the control for a short while before reloading. This livens up the coalbed. You should also break up any large chunks and distribute the coals so that the new wood is laid on hot coals.

Air quality is important to all of us and if we choose to use wood to heat our homes, we should do so responsibly. To do this we need to learn to burn our stoves in the cleanest possible way. Doing this will allow us to continue using our woodstoves for many years to come.

COMBUSTION AIR SYSTEM

The combustion air enters at the upper front of the firebox near the top of the glass door. This pre-heated air supplies the necessary fresh oxygen to keep the wood burning and mix with the unburned gases, helping to create secondary, tertiary and quaternary combustions. This air is regulated by the push rod beneath the ash catcher. For more combustion air, push the rod in. For less combustion air, pull the rod out.

FAN OPERATING INSTRUCTIONS

If your **Quadra-Fire** stove is equipped with a fan, you should follow three guidelines:

- I. **Initial (Cold) Startup:** Leave fan off until your stove is hot and a good coalbed has been established. The fan may be turned on approximately 30 minutes after loading the unit with fuel.
- II. **High Burn Setting:** The fan may be left on throughout the burn.
- III. **Medium Burn Setting:** The fan should be left off until a good burn is established, then turned on at a medium or high rate.
- IV. **Low Burn Setting:** The fan tends to cool the stove. If you are using wet wood or a very low burn setting, leave fan off until the burn is well established. Then if you wish, turn the fan on at a lower rate. Too high a fan setting with low burn rate may adversely affect emissions.
- V. The fan is equipped with a speed control. The highest fan speed is obtained by turning the speed control on and then adjusting back towards off as far as is possible without turning the fan off. For a low fan speed, turn the control clockwise as far as possible.

OPERATING TIPS

Here are a few tips on operating your **Quadra-Fire** stove to obtain the most efficiency with lowest emissions.

1. Regardless of desired heat output, when loading stove, burn your **Quadra-Fire** with the air controls wide open for a minimum of 15 minutes.
2. Regulate burn rate (heat output) by adjusting the combustion control (center, under ash catcher).
3. **Do Not Burn With Fuel Door Open.** This can cause overfiring and smoke spillage. Smoke spillage can set off smoke detectors if they are installed.

Heat Output

Low Burn
 Medium Low Burn
 Medium High Burn
 High Burn

Combustion Air Control

Pull To Stop
 Pull To Stop, Then Push 1/4" - 1/2" Open
 Pull To Stop, Then Push 1/2" - 3/4" Open
 Push Full Open

NOTE: Caution - If any part of the stove or chimney connector starts to glow, you are in an overfire situation - Close Air Control.
OVERFIRING VOIDS WARRANTY

SUMMARY OF OPERATING INSTRUCTIONS

Aladdin Steel Products is deeply concerned with the air quality in your community. In order to maintain clean air, it is very important to burn your woodstove in the most efficient manner possible. Following these guidelines will ensure environment-friendly operation.

OPACITY

This is the measure of how clean your stove is burning. Opacity is measured in percent. 100% opacity is when an object is totally obscured by the smoke column from a chimney, a 0% opacity means that no smoke column can be seen. As you become familiar with your stove, you should periodically check the opacity. This will allow you to know how to burn your stove as smoke-free as possible.

WOOD

Burn only dry seasoned wood. Store wood under cover, out of the rain and snow.

HIGH BURN RATE

Open (push in) the air control fully. It is important to do this when reloading the stove. Failure to do this could result in excessive emissions (opacity).

MEDIUM BURN RATE

After a wood load had been burning on high for at least 15 minutes (longer for very large pieces or wet wood), close (pull out) the control to the desired setting.

LOW BURN RATE

After a wood load has been burning on high for at least 15 minutes (longer for very large pieces or wet wood), close (pull out) the control gradually making sure to **Maintain Flames** in the stove. It is very important to maintain flames in your stove during the first few hours of a low burn to avoid excessive air pollution.

BEFORE YOUR FIRST FIRE

Check to see that the baffle is pushed to the rear of the stove and sitting on baffle supports. Make sure insulation blanket is in its proper location and laying flat at front of baffle.

BUILDING A FIRE

There are many ways to build a fire. The basic principle is to light easily ignitable tinder or paper, which ignites the fast-burning kindling, which in turn ignites the slow-burning firewood. Here is one method that works well:

1. Place several wads of crushed paper on the firebox floor.
2. Lay small dry sticks of kindling on top.
3. Open combustion air control fully.
4. Make sure that no matches or other combustible are in the immediate area of the stove. Be sure the room is adequately ventilated and the flue is unobstructed.
5. Light the waded paper in the stove, **NEVER** light or rekindle stove with kerosene, gasoline, or charcoal lighter fluid. Results can be fatal.
6. Once the kindling is burning quickly, add several full length logs three or four inches in diameter. Be careful not to smother the fire. Stack the pieces of wood carefully -- near enough to keep each other hot, but far enough away to allow adequate air flow between them.
7. When ready to reload the stove, add more logs. Large logs burn slowly, holding a fire longer. Small logs burn fast and hot, giving quick heat.

- Adjust the combustion air control. The more you close down the control, the lower and slower the fire will burn. The more open the control is, the more heat will be produced. As long as there are hot coals, repeating steps seven and eight will maintain a continuous fire throughout the season.

NOTE: The special high temperature paint that your stove is finished with will cure as your stove heats. You will notice an odor and perhaps see some vapor rise from the stove surface. This is normal. We recommend that you open a window until the odor dissipates and the paint is cured.

CARE AND CLEANING OF CERAMIC GLASS

Quadra-Fire stoves are equipped with ceramic super heat resistant glass which can only be broken by impact or misuse. Do not slam stove door or impact the glass. When closing the door, make sure that logs do not protrude against glass.

Clean glass with any non-abrasive glass cleaner available from your **Quadra-Fire** dealer. Abrasive cleaners may scratch and cause the glass to crack.

Inspect the glass regularly. If you find a crack or break, immediately put the fire out and return the door to your dealer for replacement of glass before further use. Do not substitute materials for glass replacement.

CARE AND CLEANING OF PLATED SURFACES

Clean 24K gold-plated surfaces with warm soapy water before lighting the first fire. Polishes with abrasive agent will scratch the finish.

CHIMNEY CLEANING

NOTE: Disconnect flue pipe from stove before cleaning chimney.

ASH REMOVAL

Remove cold ashes (never hot) from the stove by shoveling them into a metal container with a tight-fitting lid. Always treat ashes as if they contain hot coals and store the container in a non-combustible floor away from combustible material pending final disposal.

FIREBRICK

The firebox of the **Quadra-Fire** stove is lined with high-quality firebrick which has exceptional insulating properties. There is no need for a grate. Simply build the fire on the brick floor of your stove.

OVERFIRING

Do not overfire your stove. Using flammable liquids or too much wood, or burning trash in the stove, may result in overfiring. If the chimney connector or stove glows red or white, the stove is overfired. This condition may ignite creosote in the chimney, possibly causing a house fire.

If you overfire, immediately close the air control and door, if open, to reduce the air supply to the fire.

BURN WOOD ONLY

Other materials when burned can generate carbon monoxide which can result in carbon monoxide poisoning.

WOOD SELECTION AND STORAGE

Dry and well-seasoned wood will not only minimize the chance of creosote formation but also will give you the most efficient fire. Even dry wood contains 15% moisture by weight and should be burned hot enough to keep the chimney hot for as long as it takes to dry the wood being burned. It is a waste of energy to burn unseasoned wood of any kind.

Dead wood lying on the forest floor should be considered wet and requires full seasoning time. Standing wood can be considered 2/3 seasoned. To tell if wood is dry enough to burn, check the ends of the logs. If there are cracks radiating in all directions for the center, it's dry. If your wood sizzles in the fire, even though the surface is dry, it may not be fully cured. Splitting of wood before it is stored reduces drying time. Wood should be stacked that both ends of each piece are exposed to the air, if space is available, since more drying occurs through the cut ends than through the sides. This is true even with wood that has been split. Store wood under cover, such as in a shed, or covered with a tarp, plastic, tarpaper, sheets of scrap plywood, etc.

MAINTENANCE

While your **Quadra-Fire** stove has been designed to provide you with many hours of trouble free operation, there are several components which require routine checking to maintain your stove in top working condition. These actions are essential to maximize the overall efficiency (heat output) while minimizing the emissions (smoke) from your stove.

MAINTENANCE INSTRUCTIONS

CREOSOTE Formation - When wood is burned slowly, it produces tar and other organic vapors which combine with expelled moisture to form creosote. The creosote vapors condense in the relatively cool chimney flue of a newly started fire or from a slow burning fire. As a result, creosote residue accumulates on the flue lining. When ignited, this creosote makes an extremely hot fire which may damage the chimney or even destroy the house. The chimney connector and chimney should be inspected at least twice monthly during the heating season to determine if a creosote build up has occurred. If creosote has accumulated, it should be removed to reduce the risk of a chimney fire.

2. Chimney Inspection and Creosote removal - Inspect the system at the stove connection and at the chimney top. Cooler surfaces tend to build creosote deposits quicker, so it is important to check the chimney from the top as well as from the bottom. The creosote should be removed with a brush specifically designed for the type of chimney in use. A chimney sweep can perform this service. It is also recommended that before each heating season, the entire system be professionally inspected, and cleaned and repaired if necessary.

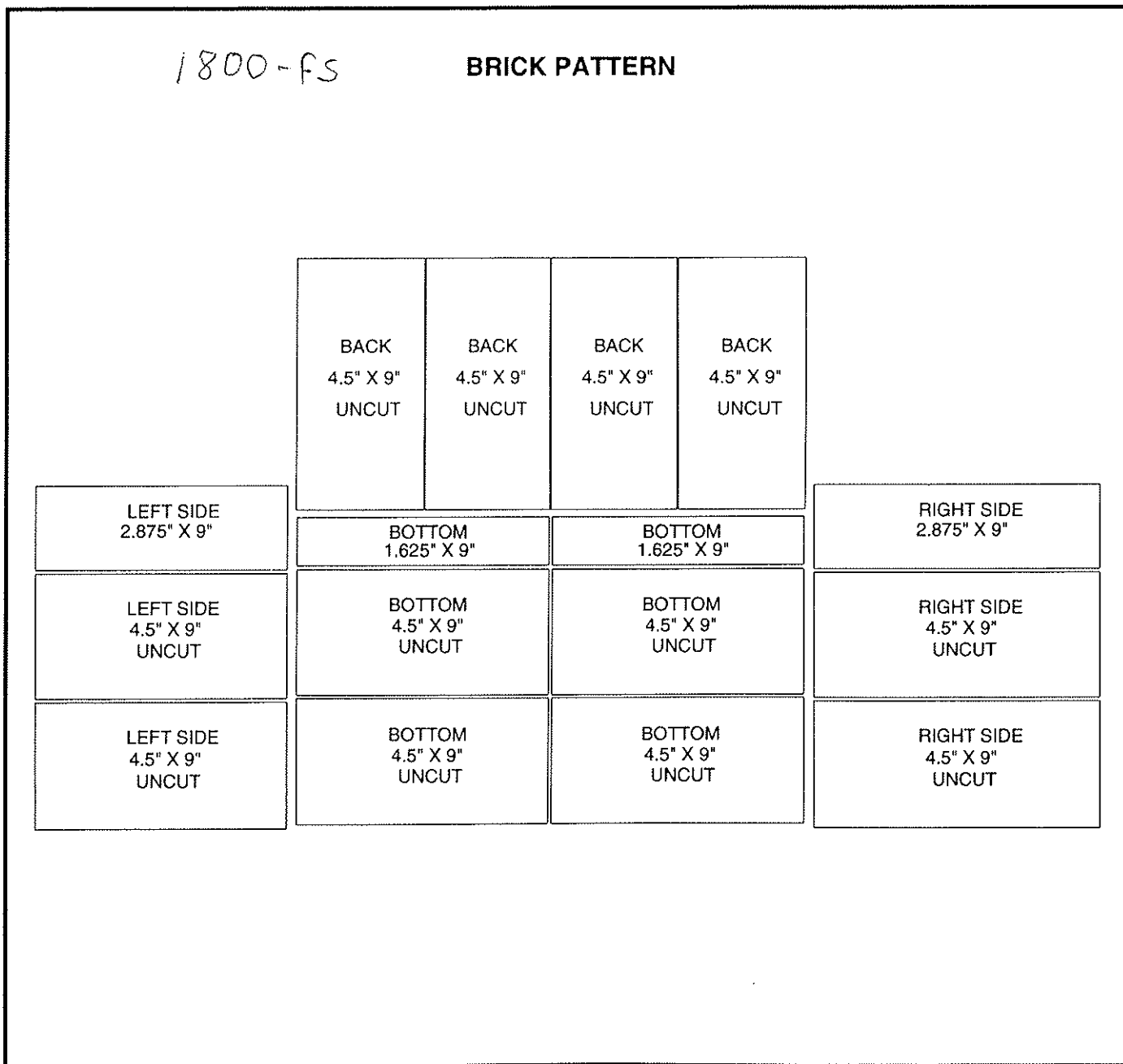

TOP HEAT SHIELD

The top heat shield (Part #831-1260) can be used to reduce clearance to combustible materials. Refer to page 3.

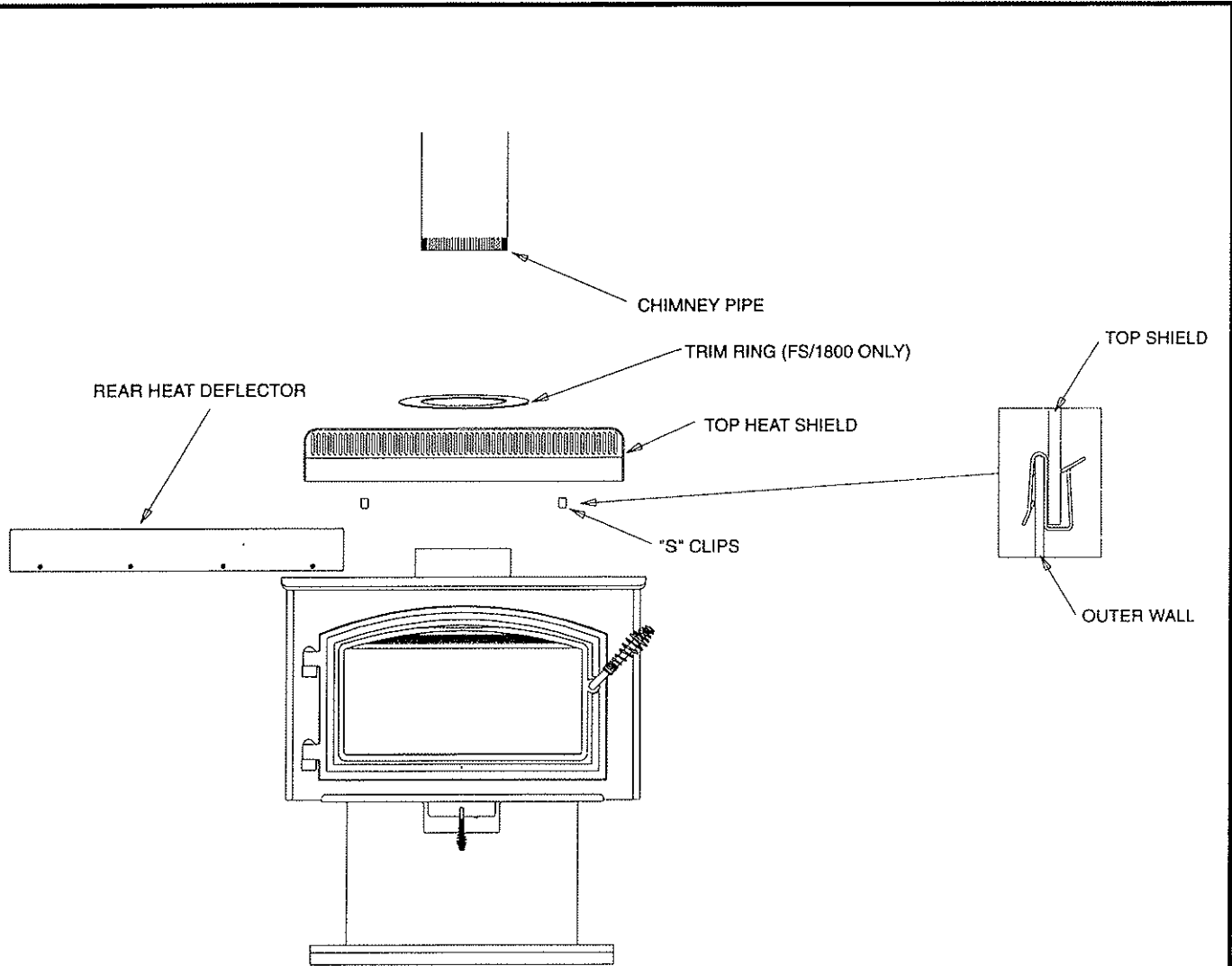

Parts Included:

- (1) Top Shield
- (1) Trim Ring
- (2) "S" Clips

Tools Needed:

No. 2 Phillips screwdriver

1. Remove the four screws in the rear heat deflector.
2. Attach the two "S" clips in rear heat shield on the stove.
3. Set top heat shield on stove and push down into "S" clips.
4. Place trim ring on top of top heat shield.
5. Install chimney pipe through hole in top heat shield.

Door Handle Assembly

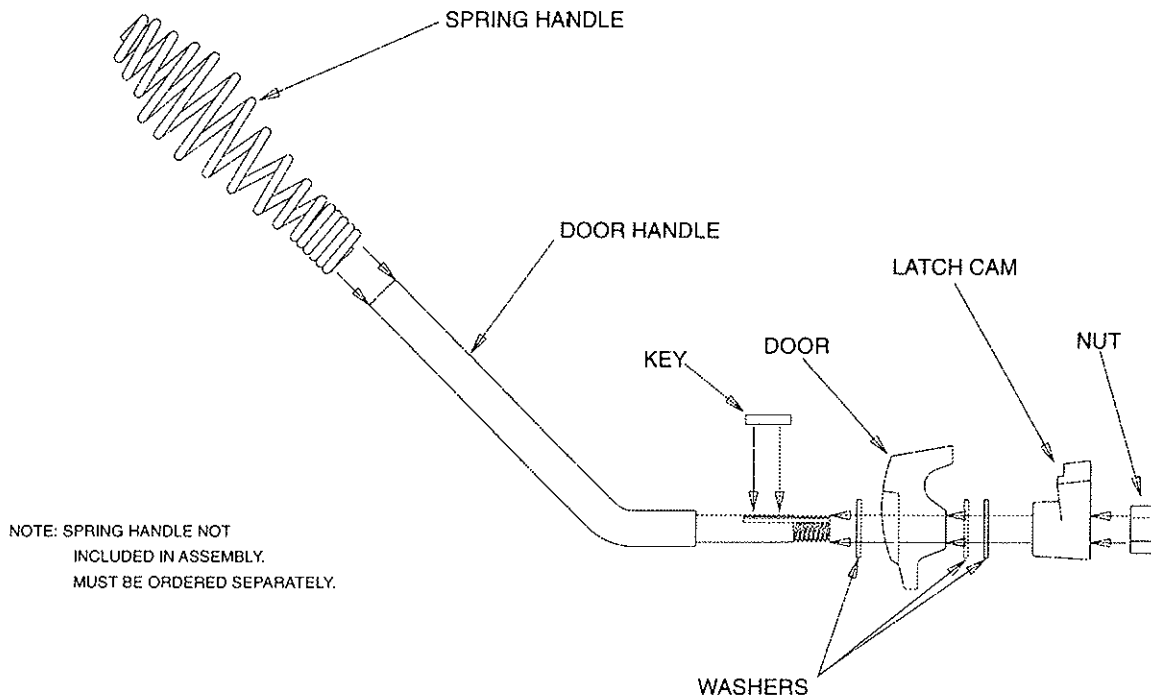

Replace Only With Ceramic Glass

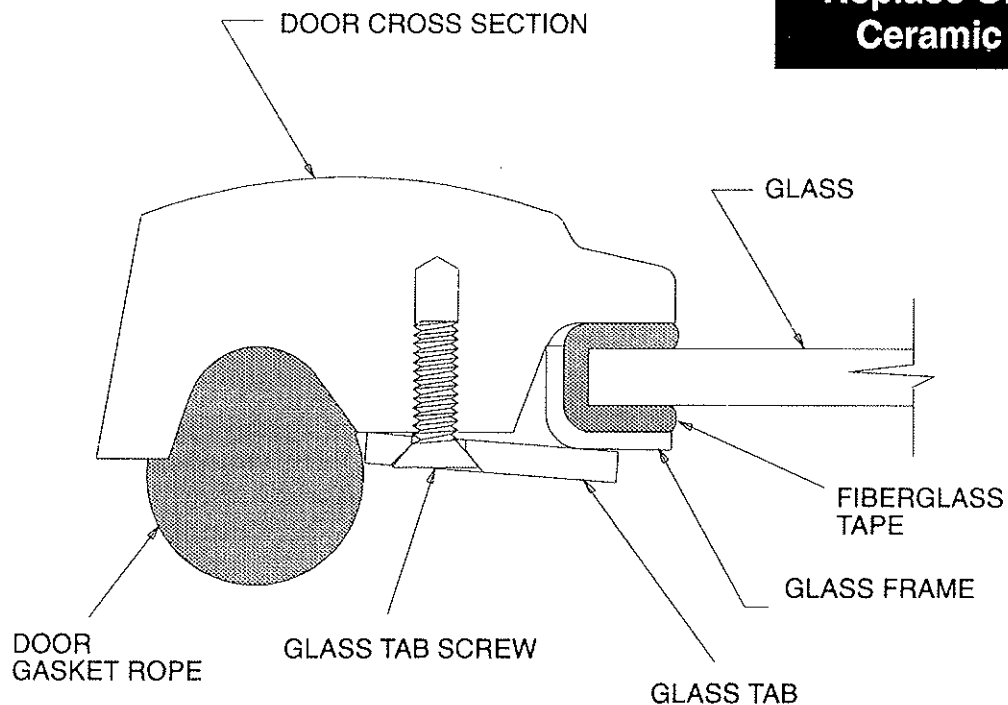

Glass Replacement Instructions

1. Remove door from stove and lay on a padded flat surface.
2. Remove glass tabs and screws with a Phillips screwdriver (Turn screws counterclockwise).
3. Lift glass frame pieces and glass out of the door frame.
4. Lay new glass with fiberglass tape around it into door frame making sure the **Quadra-Fire** logo reads correctly to the outside.
5. Place glass frame pieces over the fiberglass tape on the edges of the glass. Be sure glass is centered in the opening (i.e. same space top and bottom, left and right sides).
6. Reinstall screws and glass tabs tight enough to hold things in place.
7. Check again for centering of glass in door frame and give all screws a final tightening.

OPTIONAL FREESTANDING BLOWER INSTALLATION INSTRUCTIONS FOR QUADRA-FIRE STOVES

Tools Required:

No. 2 Phillips screwdriver
3/8 socket and ratchet, or wrench

The blower is shipped fully assembled and ready for installation.

Step

1. Remove the blower cover by removing the six No. 8 Phillips head mounting screws.
2. Position the blower so the mounting clamp slides behind the outer skin centered at the rear of the stove.
3. Tighten the three 1/4" bolt (3/8 hex head) to secure the blower to the outer skin.
4. Reinstall the blower cover and tighten the six Phillips head screws.
5. Plug the unit in and adjust the fan control as required.

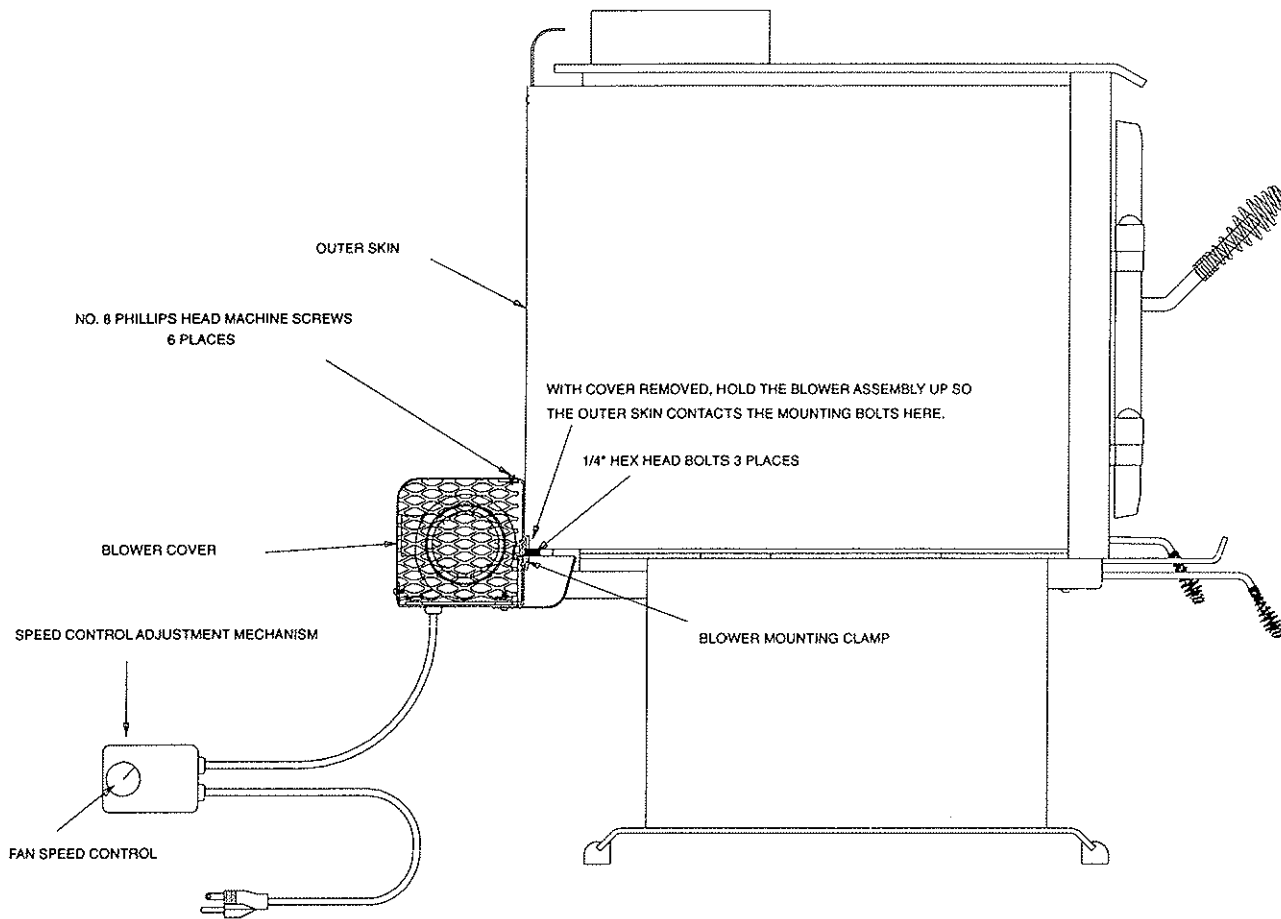

Blower Switch Adjustments

The blower switch for this unit is adjusted at the factory and should not require further adjustment. When the blower switch is turned clockwise it will click on to high speed. Turn the switch more clockwise to decrease the speed. At full clockwise the fan should blow very gently but should not stop.

Steps For Adjusting The Blower Speed Control

1. With the unit plugged in turn the speed control knob to slow. (Full clockwise)
2. With a small screwdriver adjust the fan speed by turning the adjustment mechanism through the hole on the side of the speed control.
3. Adjust the speed so the fan runs slowly, but does not stop. Turn clockwise to slow the fan and counterclockwise to increase the speed.

Baffle Removal & Installation for Model 1800

NOTE: Baffles in Quadra-Fire stoves are heavy. The 1800 Baffle weighs 25-lbs. Moving the baffle around inside the stove takes strength and patience. Removing hardware exposed to combustion processes can be frustrating. If your reason for removing the baffle is simply to clean the chimney you have alternatives that will save time and effort. Read instructions thoroughly before proceeding.

1. Remove all ash from the Firebox and extinguish all hot embers before disposal.
2. Remove the Firebrick from the sides of the stove.
4. To remove the Secondary Combustion Tubes, slide them to one side until one end is out of its hole. Then, while lifting that end of the baffle plate, pull the tube up over the Secondary Air Channel and out of the hole at its other end.

Note: The Front and Rear Secondary Tubes differ. A mark on the tube and the Manifold will insure they are replaced correctly.

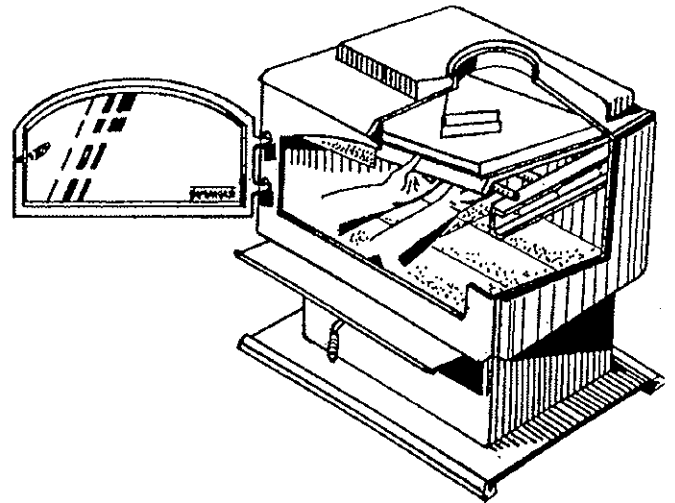
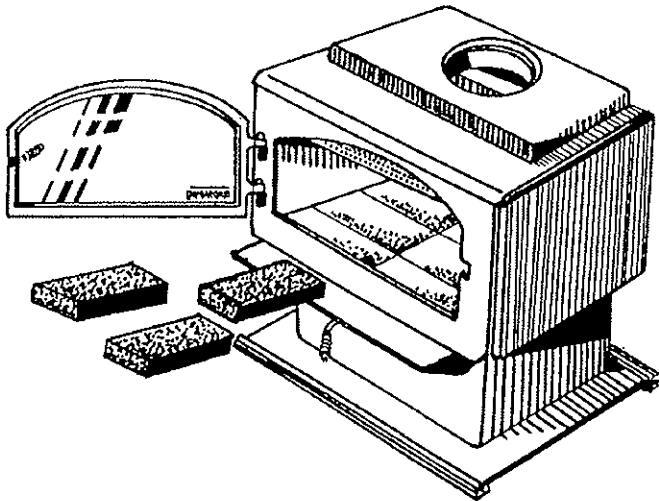

3. With a 3/16" Allen Wrench, remove the Secondary Combustion Tube Retainer Bolts on the Secondary Air Channel under the end of each tube. Note: Soak the bolts with penetrating oil at least 15 minutes before removal.

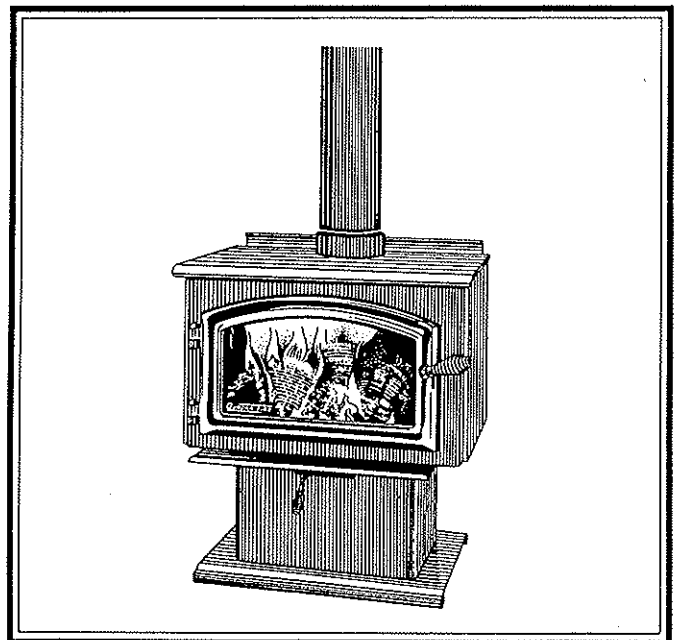
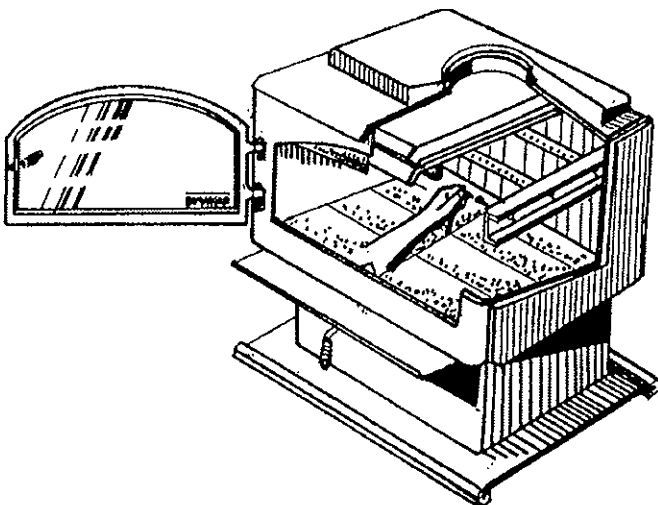

Baffle Removal & Installation for Model 1800 (continued)

5. To remove the Baffle Plate, use both hands to lift it from the alignment pin at the center rear. Then tilt it as you slide it to one side until the other side clears the shelf.

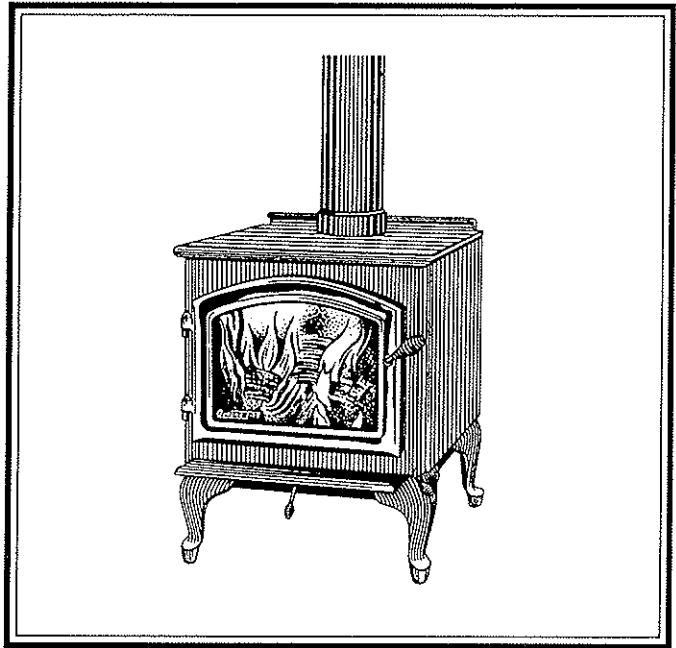
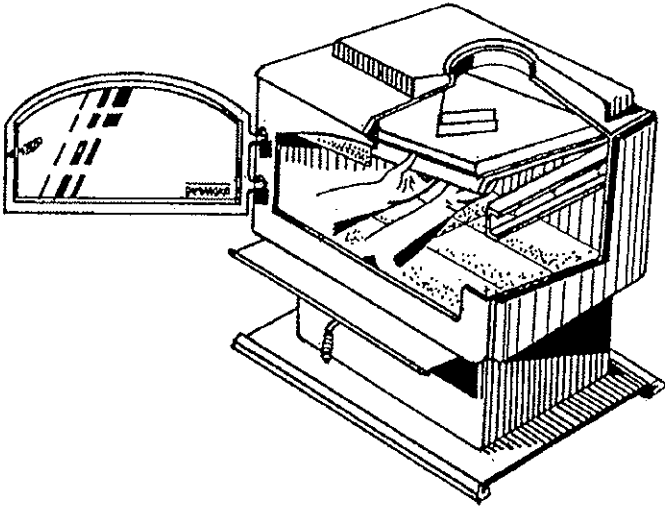

7. Keep the Baffle tilted as you lift it out the door.

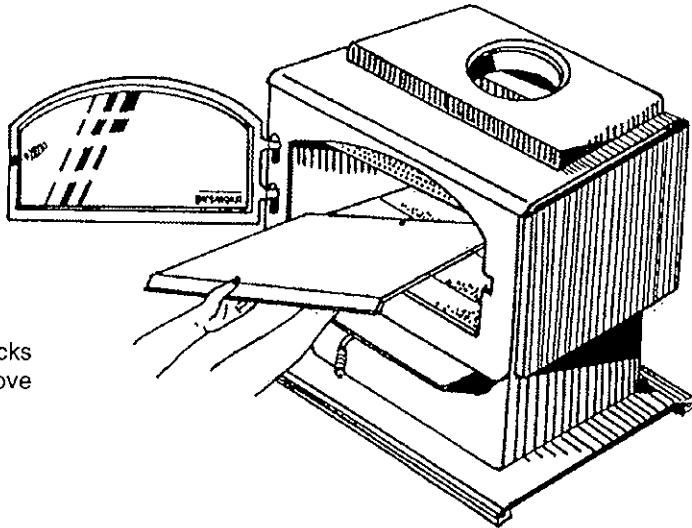

6. With one end of the Baffle resting on the bottom firebricks and the other end against the side of the Firebox, remove the Kaowool blanket.

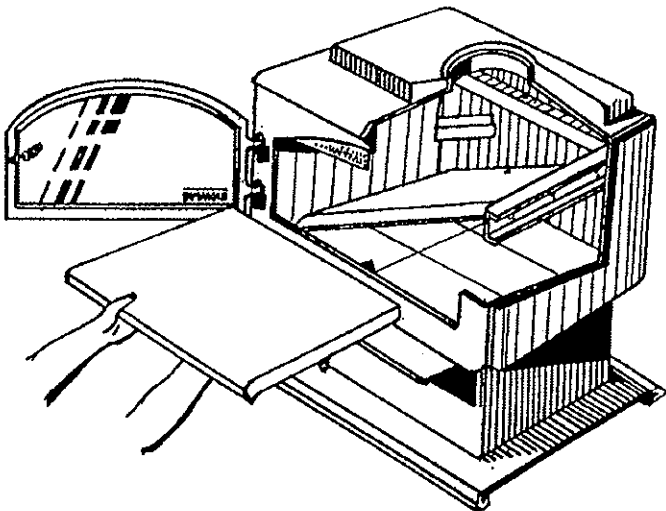

8. To replace the Baffle, reverse Steps 1 through 7. Be sure the stainless steel extension of the flame spreader is in place and resting on the Kaowool blanket. Be sure the hole in the rear of the Baffle is on the alignment pin.

ALADDIN STEEL PRODUCTS, INC. LIMITED WARRANTY

Aladdin Steel Products, Inc., warrants the **QUADRA-FIRE 1800** model against defects in materials or workmanship (except optional electrical component parts) for a period of five (5) years following the date of retail purchase. Optional electrical components parts are warranted against defects in materials or workmanship for a period of one (1) year following the date of retail purchase. Proof of purchase is required to secure warranty. To secure this warranty, the purchaser must return the warranty card within ten (10) days of the purchase to:

Aladdin Steel Products, Inc.

**401 North Wynne
Colville, WA. 99114**

The manufacturer is responsible only for repair or replacement of the defective part and may request that the purchaser ship the part to the manufacturer or authorized repair facility in your state. Warranty claims should be made to the manufacturer through your authorized dealer. The manufacture is not responsible for special, incidental or consequential damage.

Misusing or altering the stove or optional electrical component parts **VOIDS** this warranty. This included but is not limited to, using other than recommended fuels, overheating, and any alterations or modifications.

This warranty does not cover freight, glass, paint, plated surfaces, gaskets or firebrick.

QUADRA-FIRE

North America's Best

ALADDIN

ALADDIN STEEL PRODUCTS, INC.

401 N. WYNNE

COLVILLE, WASHINGTON 99114